



Classwork-1.1

Student Name: _____

Grade: $\frac{\quad}{5}$

Write a word address program in absolute mode to profile mill the contour given below. Use CNC tool and operations sheet given.

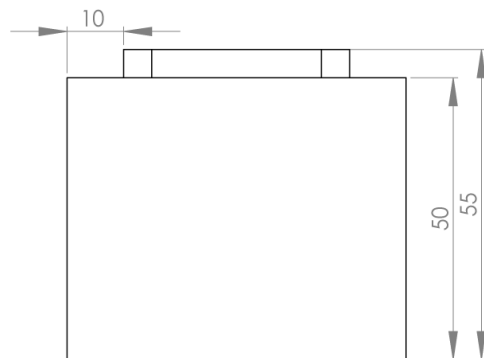
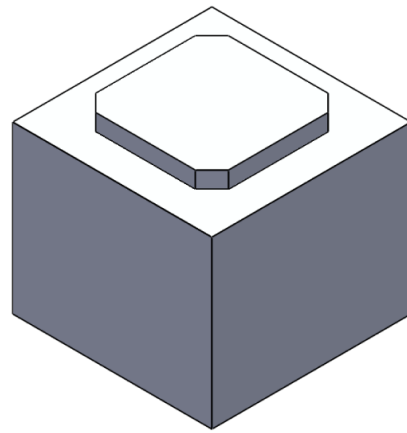
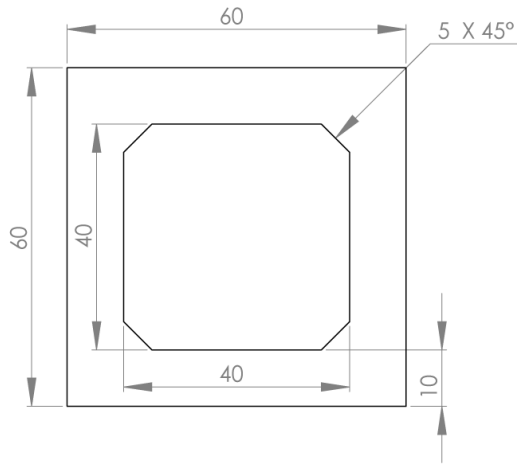

CNC TOOL AND OPERATIONS SHEET

Tool	Operation	Tooling	Speed (rpm)	Feed (mm/min)
1	Facing 0.5 mm	ϕ 50-mm Shell milling cutter	1500	250
2	Contour cut	ϕ 50-mm End mill	2000	200



SEQUENCE NUMBER	Word address command	Meaning
N5		
N10		
N15		
N20		
N25		
N30		
N35		
N40		
N45		
N50		
N55		
N60		
N65		
N70		
N75		
N80		
N85		
N90		
N95		
N100		
N105		
N110		
N115		
N120		
N125		
N130		
N135		
N140		
N145		
N150		
N155		
N160		
N165		
N170		
N175		
N180		
N185		
N190		
N195		
N200		
N205		
N210		
N215		
N220		