



Bonus-2

Student Name: _____

Grade: $\frac{\quad}{5}$

Write a word address program in absolute mode for executing drilling and contour operation as shown below. Use CNC tool and operations sheet given.

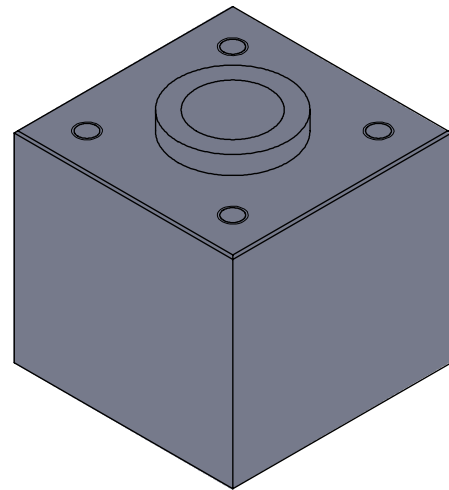
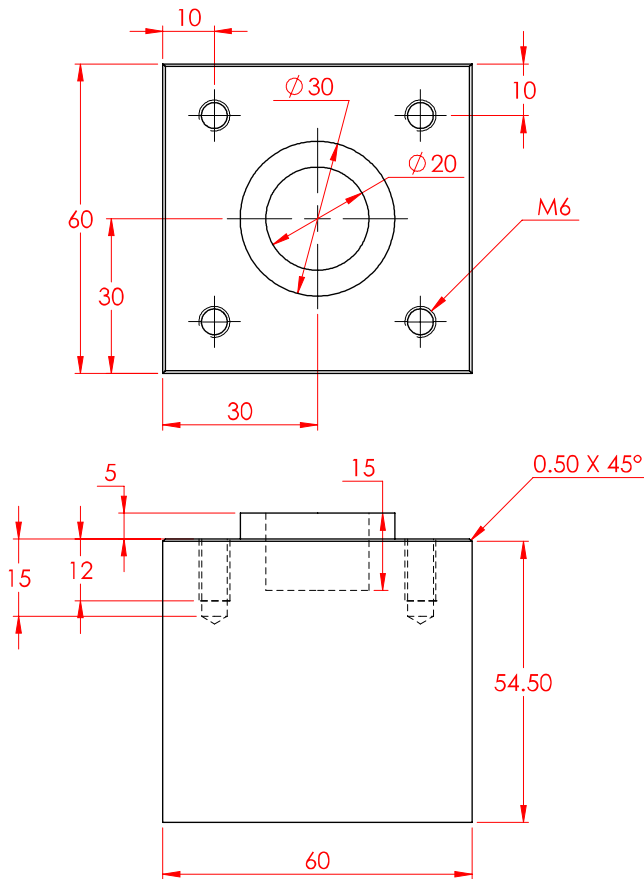

CNC TOOL AND OPERATIONS SHEET

Tool	Operation	Tooling	Speed (rpm)	Feed (mm/min)
1	Facing 0.5 mm	φ50-mm Face mill	1500	250
2	Contour cut	φ50-mm End mill	2000	200
3	Circular pocket depth of cut 2.5mm	φ10-mm End mill	2500	250
7	Center drill	Center drill	1200	100
4	Deep drill (4) holes	φ5-mm Twist drill	2000	150
5	Tapping	M6 tap	500	150
6	Chamfer mill	Angle cutter φ16x4mm	3000	400



SEQUENCE NUMBER	Word address command	SEQUENCE NUMBER	Word address command
N5		N225	
N10		N230	
N15		N235	
N20		N240	
N25		N245	
N30		N250	
N35		N255	
N40		N260	
N45		N265	
N50		N270	
N55		N275	
N60		N280	
N65		N285	
N70		N290	
N75		N295	
N80		N300	
N85		N305	
N90		N310	
N95		N315	
N100		N320	
N105		N325	
N110		N330	
N115		N335	
N120		N340	
N125		N345	
N130		N350	
N135		N355	
N140		N360	
N145		N365	
N150		N370	
N155		N375	
N160		N380	
N165		N385	
N170		N390	
N175		N395	
N180		N400	
N185		N405	
N190		N410	
N195		N415	
N200		N420	
N205		N425	
N210		N430	
N215		N435	
N220		N440	