

MET 237 COMPUTER NUMERICAL CONTROL

Eng. Ali Almandeel
 Spring 2010
 Programming Linear Profiles-Inclined Line Profiles [Milling]

9 | Inclined Line Profiles

- Determining Cutter Offsets For Inclined Line Profiles.

Many parts contain inclined line profiles in such case the programmer can not add or subtract the cutter radius. Therefore, right-triangle trigonometry must be applied to determine the position of the cutter center.

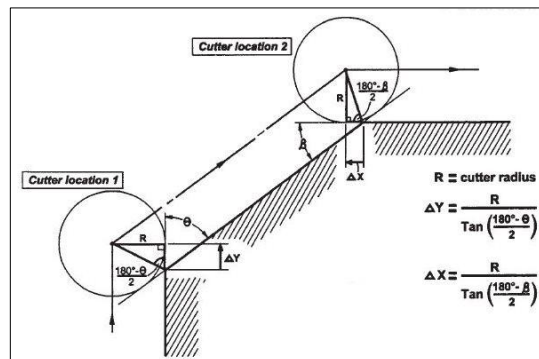

Figure 9 Inclined profile case-1.

9 | Inclined Line Profiles

- Determining Cutter Offsets For Inclined Line Profiles.

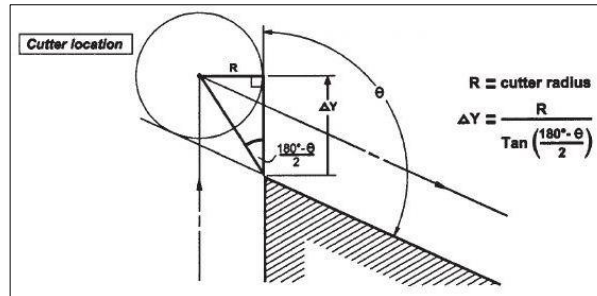

Figure 9 Inclined profile case-2.

PAAET

MET 237 | Dept. of Manufacturing Engineering Technology

9 | Inclined Line Profiles

- Determining Cutter Offsets For Inclined Line Profiles.

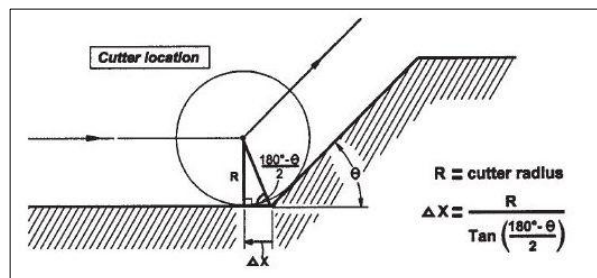

Figure 9 Inclined profile case-3.

PAAET

MET 237 | Dept. of Manufacturing Engineering Technology

9 | Inclined Line Profiles

- An Approach to Determining Cutter Offsets For Inclined Line Profiles.

Step	Procedure	Visual
1	EXTEND THE PART PROFILE LINES	
2	DRAW A CIRCLE REPRESENTING THE CUTTING TOOL TANGENT TO THE TWO EXTENSION LINES	
3	DRAW A LINE FROM THE CENTER OF THE CIRCLE TO THE INTERSECTION OF THE PART PROFILE LINES	
4	DROP A PERPENDICULAR TO THE CUT SIDE	

PAAET

MET 237 | Dept. of Manufacturing Engineering Technology

9 | Inclined Line Profiles

- An Approach to Determining Cutter Offsets For Inclined Line Profiles.

5	DETERMINE θ , THE ANGLE THE SECOND PROFILE LINE MAKES WITH THE EXTENSION LINE OF THE FIRST PROFILE	
6	THE ACUTE ANGLE OF THE RIGHT TRIANGLE AT THE INTERSECTION OF THE TWO PROFILE LINES WILL ALWAYS BE GIVEN AS: $\frac{180^\circ - \theta}{2}$	$t = \text{Tan} \left(\frac{180^\circ - \theta}{2} \right)$
7	THE CUTTER OFFSET IS DETERMINED BY DIVIDING THE CUTTER RADIUS, R, BY THE TANGENT VALUE, t	$\Delta Y = \frac{R}{t}$

PAAET

MET 237 | Dept. of Manufacturing Engineering Technology